

Status Report : January - 2001

Including TAEIG Working Group Activity Report

For external distribution - Public



HF-HWG

Human Factors-Harmonization Working Group
 Flight Crew Error / Flight Crew Performance
 Considerations in the
 Flight Deck Certification Process
 Federal Aviation Administration – USA
 Joint Aviation Authorities – Europe



Working Group	
Working Group Name	Flight Crew Error / Flight Crew Performance Considerations in the Flight Deck Certification Process (also known as Human Factors-Harmonization Working Group; HF-HWG)
ARAC issue	Transport Airplanes and Engines
Expected product(s)	NPRM <input type="checkbox"/> AC <input type="checkbox"/> Other <input type="checkbox"/> To be decided
Document	
Title	Status Report: January - 2001
Version number	2.0
Date initiated	January 15, 2001
Date of this draft	March 20, 2001
Deadline for review	January 26, 2001
Date of public release by Co-chairs	
Number of pages	30
Status	Approved by Co-chairs on March XX, 2001
Distribution	TAEIG, HF-HWG, stakeholders, unrestricted public distribution
Authors/Main Contributors	
Dr. R.C. Graeber – Co-Chair	Boeing
Mr. D. Ronceray – Co-Chair	Airbus Industrie
Mrs. S. Hecht - FAA focal point	FAA
Ms. H. Courteney - JAA focal point	UK-CAA/JAA
Mr. S. Boyd – HF-HWG Secretary	FAA
Mr. R. Nibbelke – Subgroup Communication strategy	BAE SYSTEMS

For contact details and information on how to obtain previous or future copies please refer to section 9.1.

This Status Report is part of a quarterly briefing to non-HF-HWG members.

This Status Report includes the information required in the TAEIG-Working Group Activity Report

Executive Summary

The Human Factors – Harmonization Working Group (HF-HWG) was established in 1999 following the ARAC¹/JAA² tasking (FAA³ Register Announcement 39553, Vol. 64, No. 140, July 22, 1999 / Notices). Previous initiatives have identified the importance of Human Factors of the Flight Deck Design in relation to Aircraft Safety.

The HF-HWG has 39 members. The aim of the HF-HWG is to provide ARAC and the JAA with advice and recommendations on the following harmonization task: *Flight Crew Error/Flight Crew Performance Considerations in the Flight Deck Certification Process*.

The 36-month task involves:

- reviewing existing material (FAR/JAR 25 regulations, advisory material, policy, and related references) and
- making recommendations about what regulatory standards and/or advisory material should be updated or developed to consistently address design-related flight crew performance vulnerabilities, and prevention and management (detection, tolerance, and recovery) of flight crew error.

Up until mid-January, 2001 six meetings have taken place. The most recent meeting was (see appendix B for details on previous meetings):

Meeting 6: January 9-11, 2001, Seattle, USA (hosted by BF Goodrich & Boeing)

Membership: 33

- *Types of organizations represented:*
Regulatory agencies - 8 members
Aircraft manufacturers - 14 members
Avionics manufacturers - 5 members
Research/consultant organizations - 4 members
Pilot's associations representatives - 2 members
- *Mix of experience/skills/knowledge (some people in more than one category):*
Human Factors – 22 members
Certification – 18 members
Operations 15 members
Supplemental Type Certification – 6 members
Pilots – 13 members
Designers 21 members
Training – 6 members
Rulemaking – 6 members

Most of the meeting was spent in subgroup working sessions and their reports.

Subgroup A task: Identify regulatory/guidance materials to be reviewed
Subgroup A task is considered to be complete. At the meeting it was pointed out that Change 15 to JAR 25 incorporates JAA NPAs that have been proposed for review by the HWG. Change 15 was reviewed to ensure that all relevant NPAs have been identified. FARs and Advisory Circulars were reviewed for relevance and finalized.

Subgroup B task: Develop and test (validate) a set of theory-based processes and topics

- *Following the experience of using the review process, the five Document Review Groups (DRGs) exchanged experiences and refined the process.*

¹ Aviation Rulemaking Advisory Committee

² Joint Aviation Authorities - Europe

³ Federal Aviation Administration - USA

- *The review process is intended to identify where the rules fail to deal with the key concepts. A discussion about the purpose of the different parts of the regulations clarified the 'adequacy of the regulations' in relation to the intended purpose.*

Subgroup C: Develop and test (validate) a set of experience-based processes and topics

- *This bottom-up approach reviews accident/incident data to identify human factors problems*
- *The relevant regulations and advisory material were reviewed to assess coverage of the human factors problems*
- *This process is identifying where the rules fail to prevent problematic designs*
- *Subgroup C was divided up into multiple teams*
- *The matrix that contains the data contains about 375 line items.*
- *One group is identifying specific FAR/JAR/AC deficiencies related to AC 25-11 and 25.1322 for a test case.*
- *Another group is doing preliminary work on issue-based deficiencies.*

Subgroup D: Develop a set of criteria for the future success to apply to the content of the Preliminary Report.

- *This group developed three high-level categories of criteria (aviation safety, effects on industry, industry/authority acceptance); which has been developed in more detail during the meeting.*
- *The application of the criteria to the findings (from the "regulation-based" and "topics-based" groups) will be in the form of filters.*
- *It was recommended that the highest priority be put on those findings that are supported by accident/incident data and expert judgment.*
- *Findings that are filtered out will not be "eliminated." Rather, they will be identified for referral to other groups or will be placed in a "parking lot," which will be documented in the final report.*
- *The application of the criteria to the recommendations will be in the form of a prioritization scheme. It was suggested that the intervention scoring method used in the JSAT/JSIT/JSSI process could be adapted for use. That scoring technique is dealing with similar issues and has been accepted on an international basis.*

In addition to the work being carried out in subgroups, there were plenary sessions on:

The Integration Team presented by Vic Riley

- *The output of Subgroups B&C will be restructured into two paths and then processed by two new subgroups*
 - *The regulation specific deficiencies will be collected*
 - *The conceptually based deficiencies will be collected*
- *Each of these subgroups will then produce recommendations*
- *The recommendations from the groups will then be combined and reconciled to form the main technical recommendations for Task 1.*
- *The process will need to be flexible – the later stages may need to be modified, based on what results we get from the earlier stages.*
- *The working group as a whole agreed to the process, as briefed.*
- *The process was modified so that the findings of the "regulation-based" groups and the "topics-based" group would be consolidated and then the work on the overall recommendations would be arranged and structured based on what those consolidated finding look like.*
- *This implies two places for applying group D criteria prior to forming the consolidated list of findings.*
 - *The two groups would then develop separate sets of recommendations which would subsequently be integrated, consolidated, organized and prioritized.*

The team decided that it would be advisable to test our processes, criteria, and outputs

- *A “beta test” team was established to work its way through a sample set of deficiencies identified by Subgroups B and C.*
- *The focus of the test would be on deficiencies related to FAR/JAR 25.1322 and AC 25-11, since the Avionics Systems HWG needs those inputs.*
- *The beta test team will be prepared to report on the testing and recommend any needed changes to the process at the next meeting.*

In addition, it was recommended that we test a sample of our identified deficiencies

- *It is important that the deficiencies are realistic and relevant to certification programs and problems*
- *A plan will be formulated for evaluating the validity and usefulness of the deficiencies in the context of realistic certification program scenarios.*

This status report provides some background, the tasking, the workplan, the processes developed, and information on progress, bottlenecks and future plans. The status reports will be published quarterly, for distribution to all relevant stakeholders.

Definitions of terms and abbreviations

AC	Advisory Circular
ARAC	Aviation Rulemaking Advisory Committee
CAA	Civil Aviation Authority
CRI	Certification Review Item
DRG	Document Review Group
FAA	Federal Aviation Administration – USA
FAR	Federal Aviation Regulations
HF-HWG	Human Factors – Harmonization Working Group
JAA	Joint Aviation Authorities – Europe
JAR	Joint Aviation Requirements
NPA	Notice Proposed Amendment
NPRM	Notice of Proposed Rulemaking
TAEIG	Transport Airplane and Engine Issues Group
TGL	Temporary Guidance Library
TSO	Technical Standard Order

Table of contents

Executive Summary..... 2

Definitions of terms and abbreviations 5

Table of contents..... 6

1 Introduction..... 8

 1.1 Brief history and background..... 8

 1.2 Aim..... 8

 1.3 The task 8

 1.4 Structure and organization of the working group..... 9

2 Schedule..... 11

 2.1 HF-HWG major task schedule 11

 2.2 TAEIG Working Group Activity table..... 11

3 Workplan..... 12

4 Status against workplan 14

 4.1 Introduction to Status January-2001 14

 4.2 Description of status by subgroup/process..... 15

 4.2.1 Subgroup A: Materials to be reviews..... 15

 4.2.2 Subgroup B: Top-down/Concept-based process for reviewing the regulatory material
 16

 4.2.3 Subgroup C: Bottom-up/Case-based process for reviewing the regulatory material17

 4.2.4 Subgroup D: Criteria to assessing success of the product(s) of the working group 19

 4.2.5 Integration Team..... 19

 4.2.6 Beta Test Team 22

 4.2.7 Organizational aspects..... 22

5 Bottlenecks 23

6 Actions 24

 6.1 Request for TAEIG action..... 24

7 Meetings 25

7.1 Meetings to date..... 25

7.2 Future meetings 25

8 Lessons Learned 26

9 Further information..... 27

9.1 Point of contact..... 27

9.2 References 27

Appendix A: HF-HWG members and affiliations 28

Appendix B: Summary of previous meetings..... 29

1 Introduction

1.1 Brief history and background

The Human Factors – Harmonization Working Group (HF-HWG) was established in 1999 following the ARAC⁴/JAA⁵ tasking (FAA⁶ Register Announcement 39553, Vol. 64, No. 140, July 22, 1999 / Notices). Previous initiatives have identified the importance of Human Factors of the Flight Deck Design in relation to Aircraft Safety. For example, the FAA/JAA Human Factors Team (Abbott et al, 1996) investigated and confirmed this relation and included 4 recommendations on Human Factors in Regulatory Standards and Certifications.

The FAA has established an Aviation Rulemaking Advisory Committee (ARAC) to provide advice and recommendations to the FAA Administrator, through the Associate Administrator for Regulation and Certification, on the full range of the FAA's rulemaking activities with respect to aviation-related issues. This includes obtaining advice and recommendations on the FAA's commitment to harmonize its Federal Aviation Regulations (FAR) and practices with its trading partners in Europe and Canada.

One area ARAC deals with is Transport Airplane and Engine Issues. These issues involve the airworthiness standards for transport category airplanes and engines in 14 CFR parts 25, 33, and 35 and parallel provisions in 14 CFR parts 121 and 135

The FAA requests that ARAC draft appropriate regulatory documents with supporting economic and other required analyses, and any other related guidance material or collateral documents to support its recommendations. If the resulting recommendation is one or more notices of proposed rulemaking (NPRM) published by the FAA, the FAA may ask ARAC to recommend disposition of any substantive comments the FAA receives.

An interim report is required within 18 months. The entire project shall be completed within 36 months of tasking.

The JAA supports this initiative and will consider the finding of the HF-HWG with respect to its implication for the JARs related to the above and the associated regulatory material.

1.2 Aim

To provide ARAC and the JAA with advice and recommendations on the following harmonization task:

Flight Crew Error/Flight Crew Performance Considerations in the Flight Deck Certification Process (see task description below; section 1.3).

1.3 The task

Task 1. Review relevant existing material (FAR/JAR 25 regulations, advisory material, policy, and related references) and make recommendations about what regulatory standards and/or advisory material should be updated or developed to consistently address design-related flight crew performance vulnerabilities, and prevention and management (detection, tolerance, and recovery) of flight crew error. This review should be accomplished in the context of both the Type Certification and Supplemental type Certification processes.

⁴ Aviation Rulemaking Advisory Committee

⁵ Joint Aviation Authorities - Europe

⁶ Federal Aviation Administration - USA

Task 2. Based on results of the Task 1 review, recommend new advisory material to address design-related vulnerabilities of flight crew performance and the management of flight crew error.

Task 3. Recommend (or plan for the development of) new regulatory material to address design-related vulnerabilities of flight crew performance and the management of flight crew error. If rulemaking is not recommended, provide reasons and propose non-rulemaking alternatives.

Task 4. Recommend an implementation plan for products of Tasks 1–3, and develop Terms of Reference for fulfilling the plan.

Task 5. During accomplishment of these tasks, identify implications for qualification and operations for communication to appropriate groups.

1.4 Structure and organization of the working group

The Human Factors Harmonization Working Group is composed of 39 technical experts having an interest in the assigned task. The co-chairs and FAA & JAA focal points have taken special care to ensure to maintain a balance among members:

- Industry representatives 23 and representatives from the Regulatory Authorities (11), helped by human factors researchers or consultants (5).
- 26 have an expertise in Human Factors
- 16 Pilots
- 21 have an expertise in aircraft certification
- 23 have an expertise in cockpit design
- N. American (22) and European and other representatives (17)

All members have been made aware that they are representing their organization or company and need to disseminate and check information with their organization or company.

A full list of members is provided in appendix A.

Mr. R. C. Graeber (Boeing) and Mr. D. Ronceray (Airbus Industrie) are the co-chairs of the HF-HWG. The United States co-chair shall make periodic progress reports to TAE.

Mrs. S. Hecht (FAA, ANM-111) is the FAA focal point and Mrs. H. Courteney (UK-CAA) is the JAA focal point. Mr. S. Boyd (FAA, ANM-111) is the secretary of the HF-HWG. The FAA focal point will assist the United States co-chair in preparation of material in a form for submittal to ARAC. The JAA representative will be responsible for coordination with relevant JAA Study Groups, Steering Groups and Committees.

The Human Factors Harmonization Working Group will make use of a resource web site to document its work. Research Integrations, Inc. in the United States will host this site. There will be a public area for public information, e.g.:

- Quarterly status reports
- Names of members
- Publicly available information about our tasks (Federal Register Announcement)
- Points of contact information

The rest of the web site is password protected for use by the HF-HWG members only.

The Human Factors Harmonization Working Group meets alternately between Europe and the North America to the greatest extent practicable (2 meetings in the N. America, and 2 meetings in Europe per year).

The Human Factors Harmonization Working Group will comply with the procedures adopted by ARAC (Operating Procedures for the Aviation Rulemaking Advisory Committee, October 1997 Revision) and the harmonization procedures adopted by the JAA and FAA. As part of the procedures, the working group is expected to:

1. Recommend a work plan for completion of the task, including the rationale supporting such a plan, for consideration at the meeting of ARAC to consider transport airplane and engine issues held following publication of this notice.
2. Give a detailed conceptual presentation of the proposed recommendations, prior to proceeding with the work stated in task 3.
3. Draft recommendations for appropriate regulatory action with supporting economic and other required analyses, and/or any other related guidance material or collateral documents the working group determines to be appropriate; or, if new or revised requirements or compliance methods are not recommended, a draft report stating the rationale for not making such recommendations. If the resulting recommendation is one or more notices of proposed rulemaking (NPRM) published by the FAA, the FAA may ask ARAC to recommend disposition of any substantive comments the FAA receives.
4. Provide a status report at each meeting of ARAC held to consider transport airplane and engine issues.

2 Schedule

2.1 HF-HWG major task schedule

The following schedule is proposed for the major task activities. The working group will develop a detailed schedule to ensure that the tasks will be completed on time.

Date	Milestone
January 2000	<ul style="list-style-type: none"> Define preliminary process for working group tasks Select preliminary regulatory material for review
April 2000	<ul style="list-style-type: none"> Determine if other material should be defined for review Finalized list of regulatory material for review Finalize the processes for working group tasks
July 2000	<ul style="list-style-type: none"> Complete the preliminary review of regulatory material complete Final adjustment and approval of processes
October 2000	<ul style="list-style-type: none"> Prepare the outline of first report
January 2001	<ul style="list-style-type: none"> Draft interim report complete
April 2001	<ul style="list-style-type: none"> Finalize interim report
July 2002	<ul style="list-style-type: none"> Draft Terms of Reference for follow-on activity
July 2002	<ul style="list-style-type: none"> Work complete

2.2 TAEIG Working Group Activity table

	FAA Team	Working Group	TAEIG
1) Publication of the Federal Register Notice	July 22, 1999		
2) Work Plan Approval		Dec 15, 1999	Feb 8, 2000
3) Concept Approval			
4) Preliminary T/W and Legal Support			
5) Technical Approval in HWG			
6) Economic Evaluation			
7) Formal T/W and Legal Review			
8) Technical Agreement			
9) Recommendation to FAA			

3 Workplan

Task 1. Review relevant existing material (FAR/JAR 25 regulations, advisory material, policy, and related references) and make recommendations about what regulatory standards and/or advisory material should be updated to consistently address design-related flight crew performance vulnerabilities, and prevention and management (detection, tolerance, and recovery) of flight crew error. This review should be accomplished in the context of both the Type Certification and Supplemental Type Certification processes.

Subtask 1.a This task “should be accomplished in the context of both the Type Certification and Supplemental Type Certification processes”.

- Understand relevant aspects of current and anticipated FAA and JAA Type Certification processes, including FAR/JAR 21 processes.
- Understand relevant aspects of current and anticipated FAA and JAA Supplemental Type Certification processes
- Determine whether to address TSOs and Field Approvals (to TAEIG)

Subtask 1.b The activity should “consistently address design-related flight crew performance vulnerabilities, and prevention and management (detection, tolerance, and recovery) of flight crew error”.

- Define “design-related flight crew performance vulnerabilities”
- Define “prevention and management (detection, tolerance, and recovery) of design-related flight crew error”

Subtask 1.c Develop a review process methodology and preliminary adequacy criteria.

Subtask 1.d “Review relevant existing material”

- Identify and review the following existing and developing material relevant to Part 25 type certification:
 - Regulations
 - Policies
 - Advisory circulars
 - Industry standards

Subtask 1.e Critically evaluate reviewed materials for adequacy.

Subtask 1.f “Make recommendations about what regulatory standards and/or advisory material should be updated”.

- Define criteria for determining the need for updated or new material
- Apply criteria to pertinent material
- List regulatory standards that should be updated or developed, including explanation/justification.
- List advisory material that should be updated or developed, including explanation/justification.

Task 2. Based on results of the Task 1 review, recommend new advisory material to address design-related vulnerabilities of flight crew performance and the management of flight crew error.

- Develop recommendations for new advisory material if required
- Consider the need for generic recommendations
- Consider the need for recommendations related to specific rules.
- Develop discussion paper to describe why advisory material is not recommended if necessary

Task 3. Recommend (or plan for the development of) new regulatory material to address design-related vulnerabilities of flight crew performance and the management of flight crew error. If rulemaking is not recommended, provide reasons and propose non-rulemaking alternatives.

- Develop recommendations for new regulatory material if required
- Consider the need for generic recommendations
- Consider the need for recommendations related to specific rules.
- Return to Task 2 to develop associated advisory material.
- Develop discussion paper to describe why regulatory material is not recommended if necessary

Task 4. Recommend an implementation plan for products of Tasks 1-3, and develop Terms of Reference for fulfilling the plan.

- Define tasks required for implementing recommendations
- Develop Terms of Reference for each task

Task 5. During accomplishment of these tasks, identify implications for qualification and operations for communication to appropriate groups.

- Develop a coordination plan
- Identify groups with whom coordination would be beneficial
- Develop points of contact for coordination
- Identify means for communicating with other groups
- Provide opportunities for other groups to present information
- Provide relevant information to other groups

4 Status against workplan

4.1 Introduction to Status January-2001

Up until mid-January 2001, the HF-HWG has concentrated on:

- Setting-up the working group
- Familiarization with the task and processes (including communication plan and the web-site)
- Development of workplan.
- Selecting the material to be reviewed
- Reviewing the regulations for inadequacies in the regulations and advisory material.
- Reviewing accidents, incidents and certification practice for inadequacies in the regulations and advisory material.
- Developing an analysis approach for processing the outcome of the reviews.

With respect to the workplan (up until mid-January 2001) the HF-HWG has mainly concentrated on Task 1⁷ and the development of a process for reviewing the regulatory material. To work effectively, the HF-HWG was split into 4 subgroups (A, B, C and D) to address aspects of task 1 (also taking into account the other four HF-HWG tasks described in section 1.3):

- Subgroup A: Materials to be reviewed
 - Subgroup B: Top-down/Concept-based process for reviewing the regulatory material
 - Subgroup C: Bottom-up/Case-based process for reviewing the regulatory material
 - Subgroup D: Criteria to assessing success of the product(s) of the working group
- Subgroup B and C are reviewing the regulatory material and aim to complete this by April for analysis by the whole HF-HWG.

An integration team has developed an approach to analyze the review data from Subgroup B and C.

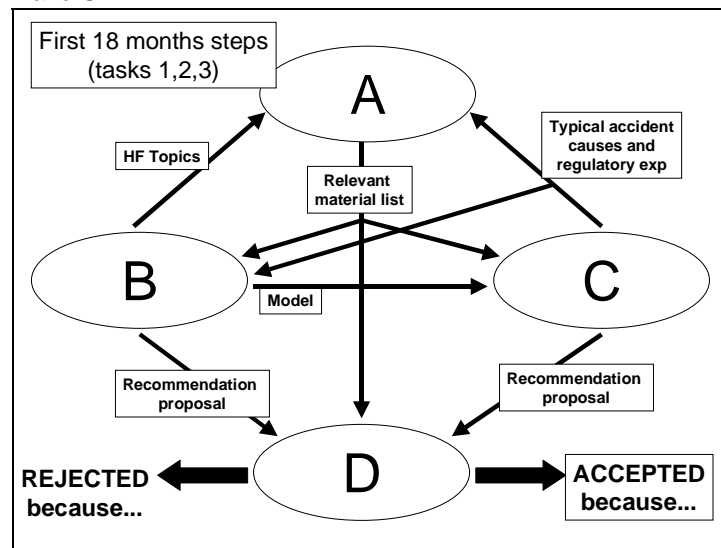

Initial model of task 1, 2 and 3 and the four processes developed by subgroup A, B, C and D.

⁷ Review relevant existing material (FAR/JAR 25 regulations, advisory material, policy, and related references) and make recommendations about what regulatory standards and/or advisory material should be updated to consistently address design-related flight crew performance vulnerabilities, and prevention and management (detection, tolerance, and recovery) of flight crew error.

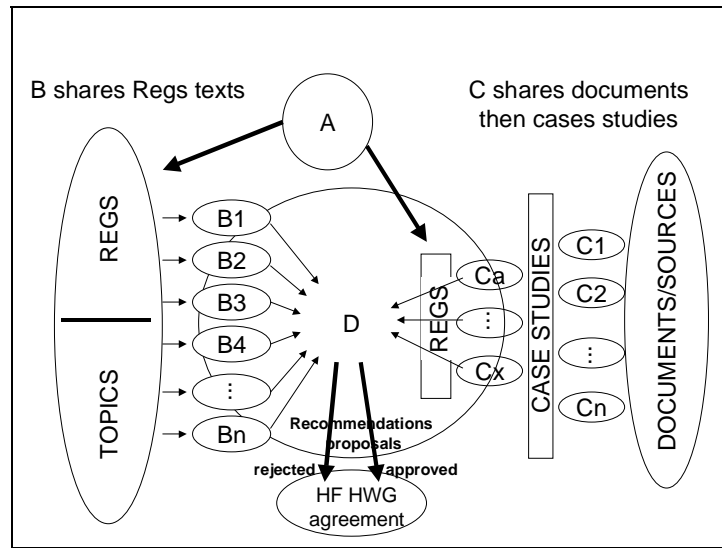

Further development of the model of task 1, 2 and 3 and the four processes developed by subgroup A, B, C and D

In addition, two further small working groups are working on organizational issues:

- Communication strategy and process subgroup
- Definitions subgroup

Members of these subgroups also take part in subgroup A, B, C or D.

The activities and status of each subgroup will be described in more detail below.

4.2 Description of status by subgroup/process

4.2.1 Subgroup A: Materials to be reviews

Subgroup A tasks are complete.

Subgroup A has identified the relevant regulatory materials which need to be reviewed by the HF-HWG using the processes developed by subgroup B and C. The main scope focuses on both FAR 25 and JAR 25 (including Change 15) and associated advisory material. A four-step plan for reviewing both the FARs and JARs has been developed (see diagram below).

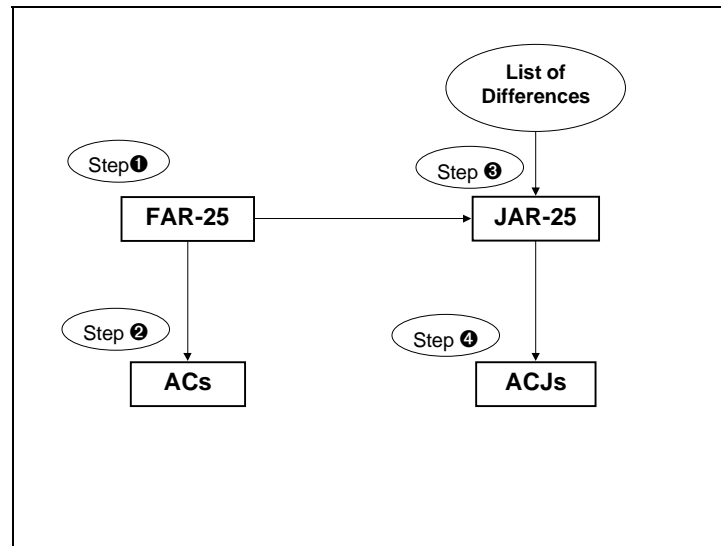

Proposals for amendments and historical information to establish the rationale for the original rules are also being considered. Subgroup A has also investigated ways of filtering the regulations for non-relevant sections by excluding parts that do not contain certain *'Human Factors Considerations'* key words. However, the rest of the HF-HWG prefers to work on the whole unfiltered material because there may be implicit Human Factors implications that would not be detected by filtering on keywords. The preliminary list for starting the review work has been completed. It has been acknowledged that the list of relevant regulatory materials may need to be updated and the subgroup will remain in place, while members can also take part in the FAR/JAR review process itself (subgroup B or C).

- Relevant NPAs have been identified and have been provided on the HF-HWG web site
- Relevant Temporary Guidance Leaflets have been identified and will be provided shortly after the October meeting.

4.2.2 Subgroup B: Top-down/Concept-based process for reviewing the regulatory material

Subgroup B developed a Top-down/Concept-based process for reviewing the regulatory material. The aim of this process is to perform a review against a list of key Human Factors/Human Error topics derived from a conceptual model of human information processing in a complex environment. This approach is complementary to the Bottom-up/Case-based process for reviewing the regulatory material as developed by subgroup C, ensuring a comprehensive review.

The Top-down/Concept-based has been used by five Document Review Groups (DRGs). Each DRG has reviewed a fifth of the regulatory material identified by subgroup A. Each DRG consists of a balanced mix of industry representatives and representatives from the regulatory authorities; Human Factors specialists and non-HF specialists; Pilots and non-pilots, US and non-US representatives. Internal cross-checking and co-ordination and comparison between DRGs has helped to ensure a consistent approach during the review.

The results from each DRG review has been captured in an EXCEL spreadsheet that represents the consensus of that DRG. These spreadsheets will be complete before the next meeting in April. Each of the five DRG spreadsheets will be reviewed by the other subgroup members and the results will be combined into a final subgroup spreadsheet that represents the regulations and advisory documents that have been identified with deficiencies along with the human factors topics that have been

determined to be generally deficient in the material reviewed. It is the subgroup's goal to have this final spreadsheet product complete by the end of the April meeting.

4.2.3 *Subgroup C: Bottom-up/Case-based process for reviewing the regulatory material*

Subgroup C has developed a Bottom-up/Case-based process for reviewing the regulatory material. The aim of this process is to identify if the regulation addresses the Human Factors/Human Error issues that have been highlighted by:

- incidents,
- accidents,
- in-service experience,
- safety studies,
- certification experience and
- research.

This approach is complementary to the Top-down/Concept-based process for reviewing the regulatory material as developed by subgroup B, ensuring a comprehensive review.

Brief description of Bottom-up/Case-based process for reviewing the regulatory material

Step 1: Compile a list of Documents

- Summary reports: Accidents/Incidents
- In service experience (ASRS, Crew)
- Safety studies (e.g., Team Report)
- Regulatory experience
- Research (e.g., FANS)

Step 1 Filter:

- Part 25 issue
- Time/ Date (Is the problem/ issue a current certification problem? Or is it only an accident/incident of an issue on old out of production airplanes (design not being certified any more).

Step 2: Identify general topics, issues, or risk areas

- Take the document(s) to be reviewed, read them, and identify the general topics, issues, or risk areas

Examples of a topic, issue, or risk:

Example of a system that a regulator thought was unsafe and should not be approved (ex. Terrain Awareness Warning System installation in the pedestal).

Another example is a specific contributing factor (that may have caused) an accident: (ex. lack of a moving map display, or the fact that the waypoint list did not come in order of proximity to the aircraft).

A third example would be a more general item, like a general risk area (ex. lack of situation awareness). Some of these general issues that will come from things like Flight Safety Foundation reports (which contain summary data from the analysis reports of multiple accidents).

These examples could be flight deck features that could have contributed.

- Identify general topics, issues, or risk areas that- potential to lead to accidents
- Find specific case studies to support each risk area or topic.
- Cross check with subgroup B

Step 2 Filter

- Flight deck, pilot interaction, Human Factors (flight crew performance)
- Time/date (modern aircraft only?)
- Safety issue
- Design related (in a broad sense)
- Is another group working this specific issue?
- Modern design covers the issue?
- Part 25 (type operation)
- Cross check within team in Montreal
- Cross check with group B

Step 3: Development of Scenario

- Describe Scenario
- Document Source
- Assumptions
- Type of Information
- Safety Risks
- Compare to Group B Model
- Describe Aircraft/ Flight Deck/ System

Step 4: Identify the Specific Human Factors Safety Issues

- Compare to group B model
- Use model to cross check

Step 5: Run Scenarios against Regulatory/ Advisory Material

- Group A provides a full list of documents

- Pick from regulatory/ advisory material
- Identify "holes"
- Identify misunderstandings

Step 6: Products/ Output

- Specific holes in the regulatory/ advisory material
- General issue that is not covered

4.2.4 Subgroup D: Criteria to assessing success of the product(s) of the working group

Subgroup D has developed a series of critical questions and success criteria and operationalised these into a decision flow-chart. This will enable to HF-HWG to assess their final product(s) and provide rationale for inclusion or rejection of recommendations and advice to ARAC and the JAA. Another aim is to include some of the criteria into the review processes being developed by subgroup B and C.

The preliminary decision flow-chart will be completed prior to the Montreal meeting but work will continue. It has been acknowledged that the criteria and decision flow-chart may need to be updated and subgroup D will remain in place, while members can also take part in the FAR/JAR review process itself (subgroup B or C).

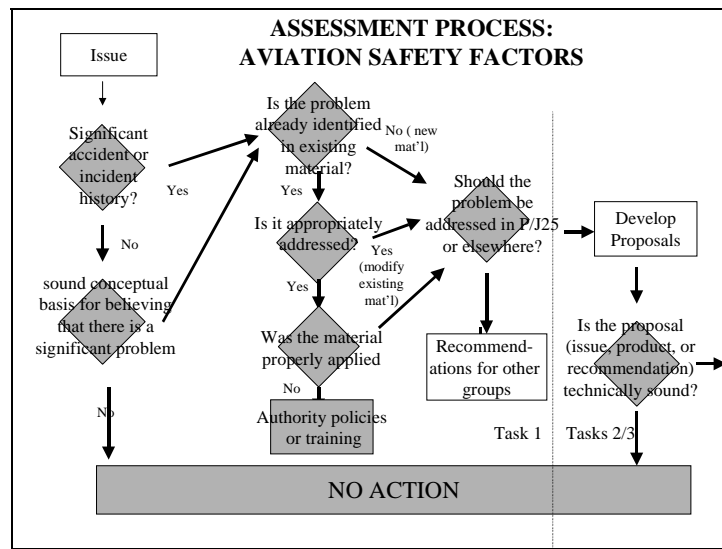

Initial version of the flow-chart developed by subgroup D

4.2.5 Integration Team

A small team representing subgroup B and C has produced an approach for integrating the two-directional data collection (as explained in section 4.2.2 and 4.2.3). The members of this Integration Team are

- Subgroup B: V. Riley (chair), B. Kelly
- Subgroup C: C. Donovan, J.F Bousquie (also a member of subgroup D)

- Develop recommended process for integrating Subgroup B & C results into a form that can be used by the entire HWG
- Recommend a scheme for organizing data into an integrated format
- Recommend an analysis process to apply Subgroup D criteria
- Propose how the HWG can best be organized to implement the scheme and conduct the final analysis

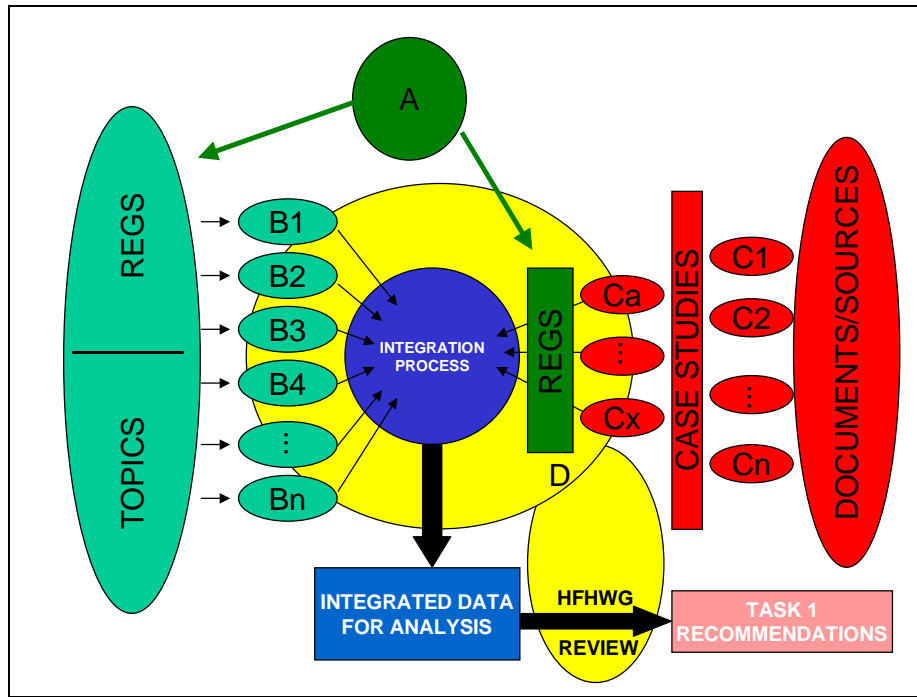

Role of the integration process in the overall process described on page 14.

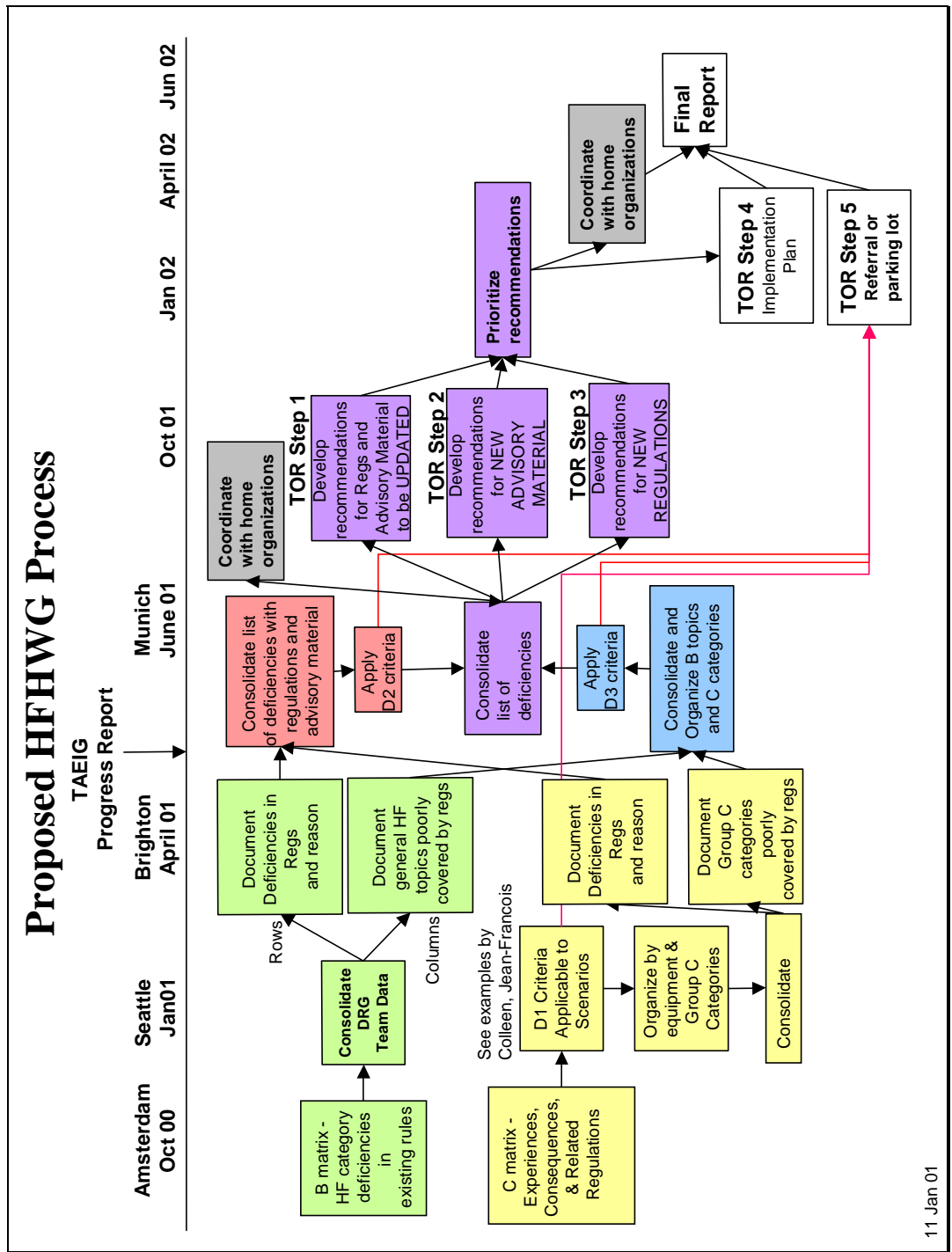

The Integration Team Process

4.2.6 Beta test team

At the meeting in Seattle, January 2001, a small group was tasked with beta testing the integration proposed. The purpose was to try out the methodology proposed with it identify recommendations for improvement for the integration process and the subgroup D criteria. The team is composed of representatives for Subgroups B, C, and D and the Integration team.

The beta test team was given the following tasks:

- To initiate the use of D criteria and to evaluate the efficiency with which the integration of B and C products can be done
- To provide to the Avionics HWG a preliminary list of identified deficiencies with the supporting data to help them to progress on the rewriting (or updating) of the AC 25-11 and 25-1322
- To provide feedback and suggestions before Brighton on how to improve the D criteria and the integration process so that they are both ready when we come to integrate the entire B and C final products.

4.2.7 Organizational aspects

Small working groups have been working on organizational issues:

Communication strategy and process subgroup

The communication strategy and process subgroup has developed:

- Communication Plan: Strategy and Process for internal and external communication
- A web-site strategy (with assistance from Jennifer Wilson at Research Integration)
- Standardization of versions of software tools used
- A template for HF-HWG documents
- Development of this Status Report for external communication to relevant stakeholders.

Definitions subgroup

The definitions subgroup has developed:

- A process for developing and approving definitions
- A preliminary list of definitions
- A template form for proposing or changing definitions

5 Bottlenecks

Through regular process checks at the meetings the co-chairs are capturing, addressing and monitoring the bottlenecks/concerns. The HF-HWG secretary logs a list of issues.

- An issue was raised regarding the time needed to consult with different, geographically spread, civil flight deck groups within one large organization. The co-chairs acknowledged that during the HF-HWG meetings the technical specialists provide their expertise and not necessarily a corporately approved view on every detailed issue. However, ultimately a HF-HWG member represents his/her organization and needs to be able to approve outputs from the HF-HWG on behalf of the organization. The co-chairs appreciated that this approval needs consultation and that this will require a reasonable time between issuing a draft report and approval of such a report.

In future status reports, consideration will be given to bottlenecks. For example:

- Information availability (Materials to be reviewed, Internet access for members,...)
- Co-ordination with other working groups/organization
- Human resources required and available effort
- Scoping of the task
- Technical/Scientific bottlenecks

6 Actions

6.1 Request for TAEIG action

- TAEIG has determined that TSOs and Field Approvals are not within the current scope.
- TAEIG clarified how and when to consult with organizations not represented on the HF-HWG. TAEIG is aware of members no longer attending from organizations like ATA.

7 Meetings

7.1 Meetings to date

The following meetings were held to date:

Purpose	Date	Location	Participation
Introduction and education of the HF-HWG	6-7 Oct 1999	Boeing –Seattle US	25 HF-HWG members
Definition of working methods, review process and scope, and adequacy criteria	11-13 Jan 2000	Airbus – Toulouse FR	38 HF-HWG members
Finalization of HWG methods and processes, task sharing.	4-6 Apr 2000	Honeywell – Phoenix US	31 HF-HWG members
Subgroups work progress and report, cross subgroup coordination. Define contact with other HWGs	27-29 Jun 2000	Bombardier - Montreal	39 HF-HWG members
Continue Subgroup Analysis Activities Develop Interim Report Outline	3-5 Oct 2000	NLR – Amsterdam	35 HF-HWG members
Prepare draft Interim Report Agree on Integration Scheme	9-11 Jan 2001	BF Goodrich/ Boeing – Seattle US	33 HF-HWG members

7.2 Future meetings

Purpose	Date	Location	Participation
Finalize Interim Report, Complete Task 1, finalize integration process and reorganize the group accordingly.	3-5 April 2001	UK CAA - Brighton, UK	
State on how tasks 2 and 3 can be done according to the process and method chosen. Progress reports on these tasks.	19-21 June 2001	Domier, Munich, Germany	

8 Lessons Learned

This section is to be completed at the end of the task. Some initial lessons learned can already be reported and will be explained in more detail at a later date, namely:

1. Composition of the working group: a good balance of expertise, backgrounds, nationalities was achieved (see section 1.4).
2. Processes for internal and external communication: Lessons will be learned regarding the use of a communication plan (incl. the use of the Web-site and a Status Report for external communication). The effectiveness of the plan is currently under review. See section 4.2.5.
3. Development of regulation review approaches. Lessons will be learned regarding the two approaches developed for reviewing the regulations (see section 4.2.2 and 4.2.3).
4. Definition of terms; Lessons will be learned regarding the use of a definition subgroup and a definitions process (see section 4.2.5).
5. In this group, two quite different kind of members are present: HF specialists and aviation sector professionals (design, certification, operations). If the subject involved is common, the approach and the words used are quite different leading to lack of mutual understanding. Time is needed for them to develop a "common language" for useful dialogue.
6. For about a third of our members, the native language is not English. As we need them to participate effectively, precautions have to be taken by the speakers to speak clearly, and slowly enough, and by the co-chairs to ensure that these members can effectively follow and take part in the discussions.

9 Further information

9.1 Point of contact

- Previous issues of the Status Report can be obtained from the HF-HWG Website:

www.researchintegrations.com/hf-hwg/index.htm

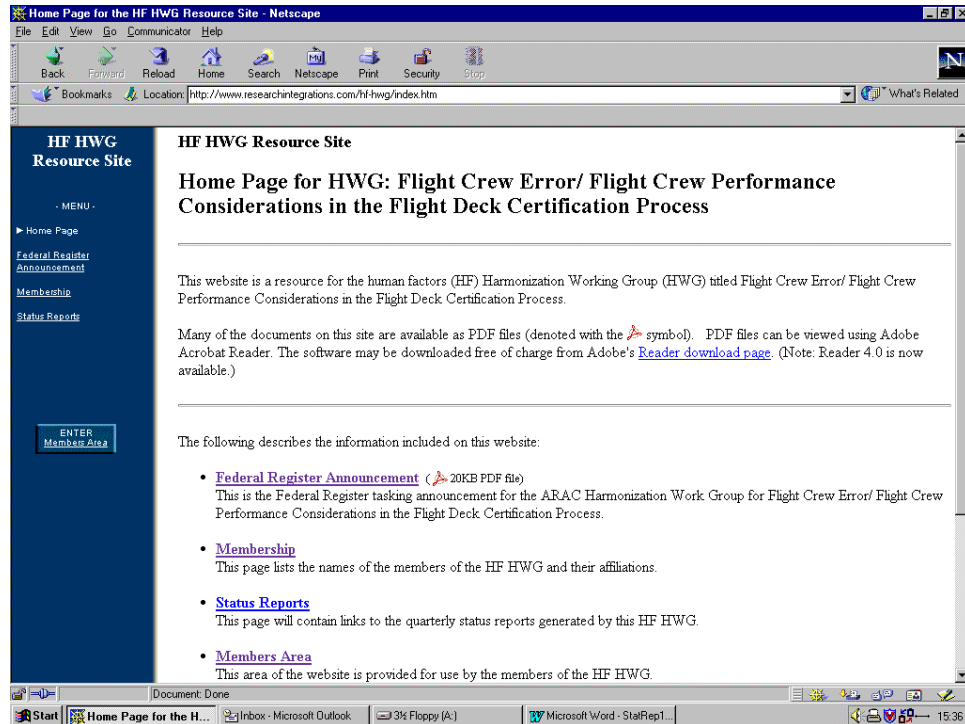

- To receive a the Status Report by email every quarter, please send an email to:

Jennifer.Wilson@ResearchIntegrations.com

- For any questions or comments please send an email to HF-HWG central email address:

9-ANM-111-HUMAN-FACTORS@faa.gov

or write to:

**Mr. Steve Boyd, HF-HWG Secretary
FAA – Transport Airplane Directorate
ANM-111
1601 Lind Ave, SW
Renton, WA 98045
United States of America**

9.2 References

Abbott, K. et al (1996) FAA Human Factors Team Report on: The interfaces between flight crews and modern flight deck systems. Published on 18 June 1996.

FAA Register Announcement 39553 Vol. 64, No. 140 / Thursday, July 22, 1999 / Notices

Appendix A: HF-HWG members and affiliations

Name	Company & Organization
1. Abbott, Kathy	FAA, Flight Deck Human Factors NRS
2. Armstrong, Don (alternate Guy Thiel)	FAA, ANM 160L
3. Beaujard, Florence	Aerospatiale-Matra Airbus
4. Birowo, Imam	Dornier Luftfahrt
5. Bousquié, Jean-François	Airbus Industrie
6. Boyd, Steve (Secretary)	FAA, ANM-111, Transport Airplane Directorate
7. Bresley, Bill (alternate: Ann Berner)	Universal Avionics
8. Carr, Tom	Raytheon
9. Courteney, Hazel (JAA focal point)	CAA SRG D&PSD Human Factors
10. Deharvengt, Stéphane (alternate: Rémi Jouty)	DGAC
11. Donovan, Colleen	FAA, AIR-130
12. Fabre, François	DGAC Flight Test Certification
13. Gagnon, Pierre	Bombardier Aerospace
14. Garloch, Julie	Rockwell Collins Air Transport Systems
15. Glover, Howard (alternate: Daryal Kuntman)	Honeywell (Allied Signal)
16. Graeber, Curt (Co-Chair)	Boeing Commercial Airplane Group
17. Harris, Don	Cranfield University
18. Hecht, Sharon (FAA focal point)	FAA, ANM-111 Transport Airplane Directorate
19. Hollop, Christine	Boeing Commercial Airplane Group
20. Imrich, Tom	FAA, Flight Operations NRS
21. Jorna, Peter	NLR Amsterdam
22. Kelly, Brian (alternate: Jean Crane)	Boeing Commercial Airplane Group
23. Kimball, Ken	Cessna Aircraft Co.
24. Lawrence, Simon (alternate: Bill Best)	ALPA (US Airways)
25. Leard, Tom (alternate: Dave Pepitone)	Honeywell Inc., Commercial Flight Systems
26. Lyall, Beth	Research Integrations, Inc,
27. May, Doug (alternate: TBD)	Bombardier Aerospace – Lear
28. Newman, Terry	CAA Flight Test
29. Nibelke, René (alternate: Paul Emmerson)	BAE SYSTEMS, Advanced Technology Centres - Sowerby
30. Proust, Jean Michel	Air France
31. Reinhold, Svenja	Dornier Luftfahrt
32. Reuzeau, Florence	Aerospatiale Matra
33. Riley, Vic	Honeywell International Labs
34. Ronceray, Didier (Co-Chair)	Airbus Industrie
35. Singer, Gideon	SAAB
36. Starr, Alison	Smiths Industries
37. Strilesky, Paula	IFALPA (Air Canada)
38. Stephen, Don	Transport Canada

Appendix B: Summary of previous meetings

Meeting 1: Oct 6-9, 1999, Seattle/Renton, Washington (hosted by Boeing)

Membership:

- *Types of organizations represented: 2 regulatory agencies; 8 Aircraft manufacturers ; 5 Avionics manufacturers; 2 Two Research/consultant organizations*
- *Mix of experience/skills/knowledge (some people in more than one category): Human Factors – 24; Certification – 25; Operations – 22; Supplemental Type Certification – 9; Pilots – 17; Designers – 22; Training – 4; Rule making – 7.*

Team processes were established

- *We will set goals for each meeting and measure our performance against them*
- *We will communicate between meetings via email and a dedicated website (<http://www.researchintegrations.com/hf-hwg/>, which was demonstrated during the meeting).*

Background briefings were provided

- *Current and planned human factors activities within the US and European regulatory agencies*
- *The FAA rulemaking process: ARAC history, purpose, and procedures.*
- *The components of a HF-HWG work plan*

The Tasking of the HF-HWG was reviewed and discussed. Relevant issues for each task were documented.

A draft Statement of Work was reviewed. Subgroups were formed to identify concerns and opportunities for the HF-HWG. There was a preliminary discussion of working process for the HF-HWG.

Subteams were formed for:

- Definition of terms
- Communications processes

Meeting 2: January 11-13, 2000, Toulouse, France (hosted by Airbus)

Membership (broadened, compared to first meeting):

- *Types of organizations represented: 4 regulatory agencies; 9 Aircraft manufacturers ; 6 Avionics manufacturers; 5 Research/consultant organizations; 2 pilot unions.*

There was a detailed discussion of the HF-HWG tasking with respect to the Statement of Work.

Temporary subgroups were formed to formulate ideas on HF-HWG work:

- *The processes we will use to perform Task 1*
- *The scope of the review process*

There was a briefing on the JAA rulemaking process

Four new subgroups were formed, balanced by skill, background, and N. America vs. Europe, to discuss and provide proposals for the following four subject areas:

- *Subgroup A: Identify regulatory/guidance materials to be reviewed*
- *Subgroup B: Develop and test (validate) a set of theory-based processes and topics*
- *Subgroup C: Develop and test (validate) a set of experience-based processes and topics*
- *Subgroup D: Develop a set of criteria for the future success to apply to the content of the Preliminary Report.*

Meeting 3: April 4-6, 2000, Phoenix, Arizona (hosted by Honeywell)

Most of the meeting was spent in subgroup working sessions and their reports.

Subgroup A: Identify regulatory/guidance materials to be reviewed

- *FARs and Advisory Circulars were reviewed for relevance*
- *Preliminary lists generated; to be finalized prior to next meeting*

Subgroup B: Develop and test (validate) a set of theory-based processes and topics

- *This top-down approach systematically reviews all regulations identified by Subgroup A.*
- *A set of key human factors concepts (e.g. input, response, control, environment) are evaluated against each regulation.*
- *This process is intended to identify where the rules fail to deal with the key concepts.*

Subgroup C: Develop and test (validate) a set of experience-based processes and topics

- *This bottom-up approach reviews accident/incident data to identify human factors problems*
- *The relevant regulations and advisory material are then reviewed to assess coverage of the human factors problems*
- *This process is intended to identify where the rules fail to prevent problematic designs*

Subgroup D: Develop a set of criteria for the future success to apply to the content of the Preliminary Report.

- *This group developed three high-level categories of criteria (aviation safety, effects on industry, industry/authority acceptance); these will be developed in more detail*
- *These criteria will be incorporated into a process by which the work of subgroups B and C can be evaluated.*
- *The criteria and process should be imbedded into the subgroups B and C processes*

The following agreements were reached:

- *Subgroup A would be dissolved when the review list is complete (prior to next meeting)*
- *Subgroup D would be dissolved when the process and criteria details are completed (prior to next meeting), but would reconvene to deal with any subsequent process or criteria issues.*
- *The concept-based and experience-based process (from Subgroups B and C) would be run in parallel. The differences in the approaches are likely to yield different and complementary insights.*

Meeting 4: June 27-29, 2000, Montreal, Canada (hosted by Bombardier)

Membership: 39

- *Types of organizations represented: 10 regulatory agencies; 16 Aircraft manufacturers; 6 Avionics manufacturers; 4 Research/consultant organizations; 3 Pilot's associations representatives.*
- *Mix of experience/skills/knowledge (some people in more than one category): 25 Human Factors; 19 Certification; 18 Operations; 9 Supplemental Type Certification; 16 Pilots; 22 Designers; 7 Training; 6 Rule making.*

Most of the meeting was spent in subgroup working sessions and their reports.

Subgroup A: Identify regulatory/guidance materials to be reviewed

- *FARs and Advisory Circulars were reviewed for relevance and finalized.*

Subgroup B: Develop and test (validate) a set of theory-based processes and topics

- *Following the experience of using the review process, the five Document Review Groups (DRGs) exchanged experiences and refined the process.*
- *The review process is intended to identify where the rules fail to deal with the key concepts. A discussion about the purpose of the different parts of the regulations clarified the 'adequacy of the regulations' in relation to the intended purpose.*

Subgroup C: Develop and test (validate) a set of experience-based processes and topics

- *This bottom-up approach reviews accident/incident data to identify human factors problems*
- *The relevant regulations and advisory material were reviewed to assess coverage of the human factors problems*
- *This process is identifying where the rules fail to prevent problematic designs*

Subgroup D: Develop a set of criteria for the future success to apply to the content of the Preliminary Report.

- *This group developed three high-level categories of criteria (aviation safety, effects on industry, industry/authority acceptance); which has been developed in more detail during the meeting.*
- *These criteria will be incorporated into a process by which the work of subgroups B and C can be evaluated.*
- *The criteria and process should be imbedded into the subgroups B and C processes*

In addition to the work being carried out in subgroups, there were plenary sessions on:

- Understanding the Avionics HWG activities and their HF needs (presentation by Kirk Baker and Clark Badie).
- Sharing information on the regulatory process, rules and supporting regulatory material, and the certification process (presentation by Hazel Courteney (CAA/JAA) and Tom Imrich (FAA))
- The definition of 'design-related' was discussed because it is an important concept in the Terms of Reference of the HF-HWG, which should be used to scope our activity. The definitions proposed are available to the members on the web-site.
- The draft table of contents for the interim 18-month report to the TAE.

The following agreements were reached:

- Definition of the working relationship between the HF HWG and the Avionics HWG include a proposal to have meetings at the same time and place.
- Interaction with other relevant HWGs was defined through nominated points of contact.
- A draft table of contents for the interim 18-month was agreed.

Meeting 5: October 3-5, 2000, Amsterdam, the Netherlands (hosted by NLR)

Membership: 35

- *Types of organizations represented: 9 regulatory agencies; 14 Aircraft manufacturers ; 5 Avionics manufacturers; 5 Research/consultant organizations ; 3 Pilot's associations representatives.*
- *Mix of experience/skills/knowledge (some people in more than one category): 25 Human Factors; 18 Certification; 14 Operations; 8 Supplemental Type Certification; 12 Pilots; 20 Designers; 5 Training; 5 Rule making.*

Most of the meeting was spent in subgroup working sessions and their reports. The work started in Montreal was continued, but in more detail.

- *Subgroup A and D met to discuss their tasks, but spent most of their time as part of subgroup B and C.*
- *At the end of the meeting group B had reviewed the majority of the regulatory material.*
- *Group C continued to work on reviewing accident/incident data to identify human factors problems. This process aims to identify where the rules fail to prevent problematic designs*

In addition to the work being carried out in subgroups, there were plenary sessions on:

- Understanding the Avionics HWG activities and their HF needs
- Discussion on the contents for the interim 18-month report to the TAE, including planning of the contributions of the different subgroups.
- An integration team was tasked to facilitate the process of integrating the outputs from subgroup B and C.